



Monofacial

Bifacial

# LP182\*210-M-66-NB N-Type TOPCon Dual Glass

Rated Power 610-640W

Power Tolerance: 0~+5 W

**FIBERGLASS FRAME**

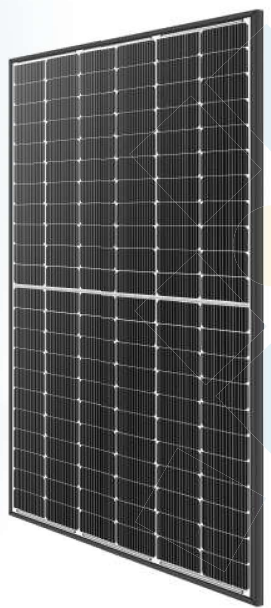

**N-Type 182\*210mm Cell**  
Adopting the 182\*210mm N-Type TOPCon battery cells with the highest efficiency.



**Low Light Features**  
Higher performance under low light environment.



**Superb corrosion resistance**  
With fiberglass frame, resistant to salt spray and ammonia. Can be installed in any environment.



**Maintains its shape**  
Fiberglass has highly resistant to deformation, even in extreme conditions like high temperature and humidity.



**Bifacial with dual glass**  
Module adopts 182\*210mm half cells, bifacial module provide an additional 5%~25% output.



**PID Protection**  
Ensure the attenuation probability caused by PID phenomenon is minimized.



**Harsh Environmental Adaptability**  
Strict salt spray and ammonia corrosion test by TUV Nord.



**Load Capacity**  
Mechanical load tests including wind load 2400 Pa and snow load 5400 Pa done by TUV Nord.

Leapton N-Type Linear Power Warranty Industry Warranty

0.4% Annual Degradation over 30 years

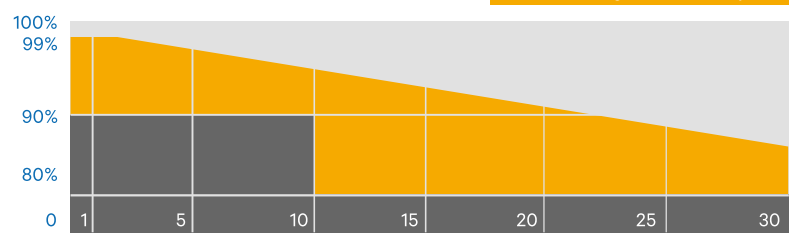

Headquarter : Leapton Energy Co., Ltd.

Tosei Bldg. 6F, 1-2-1 Aioido-cho, Chuo-ku Kobe-shi, Hyogo, 650-0025, Japan

+81-78-382-3182

www.leaptonenergy.jp

Manufacturer : Leapton Solar (Changshu) Co., Ltd.

No.9, Sunshine Avenue, Changshu City, Jiangsu, China

+86-512-88800068

info@leaptonenergy.com

www.leaptonpv.com



## MECHANICAL DIAGRAMS

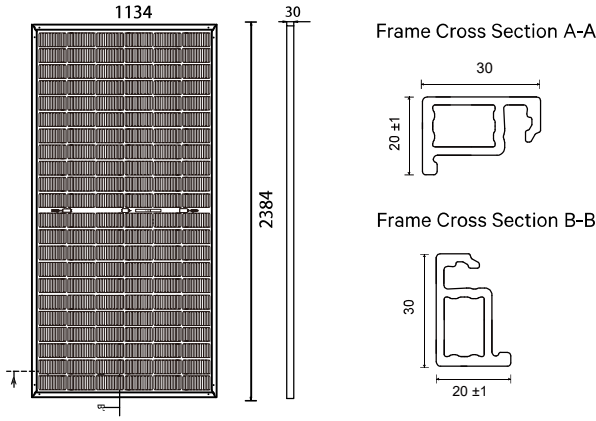

## SPECIFICATIONS

Weight	34.5kg
Dimensions	2384mm*1134mm*30mm
Cell Dimensions	182*210mm
Cell type	Mono Si
Cell Amount	66*2 pcs
Maximum System Voltage	1500V
Junction Box	IP68
Front glass	2.0mm, Anti-Reflection Coating
Back glass	2.0mm, Heat Strengthened Glass
Frame	Fiberglass
Cable	4mm <sup>2</sup> , N 1400mm/P 1400mm for Horizontal installation 4mm <sup>2</sup> , N 300mm/P 300mm for Vertical installation
Connector	MC4 compatible
Bifaciality	80±5%

## ELECTRICAL PARAMETERS AT STC

Power	610W	615W	620W	625W	630W	635W	640W
Open Circuit Voltage	49.05V	49.35V	49.55V	49.75V	49.95V	50.15V	50.35V
Short Circuit Current	15.84A	15.88A	15.93A	16.00A	16.05A	16.11A	16.17A
Maximum Power Voltage	40.66V	40.86V	41.06V	41.26V	41.46V	41.66V	41.86V
Maximum Power Current	15.00A	15.05A	15.10A	15.15A	15.20A	15.24A	15.29A
Module Efficiency	22.58%	22.77%	22.95%	23.14%	23.32%	23.51%	23.69%

\* Under Standard Test Conditions (STC) of irradiance of 1000 W/m<sup>2</sup>, spectrum AM 1.5 and cell temperature of 25°C. \* Measuring tolerance: ±3%

## ELECTRICAL PARAMETERS AT NMOT

Power	465W	469W	472W	476W	480W	484W	488W
Open Circuit Voltage	46.51V	46.81V	47.01V	47.21V	47.41V	47.61V	47.81V
Short Circuit Current	12.78A	12.81A	12.84A	12.88A	12.93A	12.98A	13.03A
Maximum Power Voltage	38.20V	38.40V	38.60V	38.80V	39.00V	39.20V	39.40V
Maximum Power Current	12.17A	12.21A	12.23A	12.27A	12.31A	12.35A	12.39A

\* Under Nominal Module Operating Temperature (NMOT), irradiance of 800 W/m<sup>2</sup>, spectrum AM 1.5, ambient temperature 20°C, wind speed 1 m/s.

## ELECTRICAL PARAMETERS ( AT 10% BIFACIAL POWER OUTPUT )

Output Power	671W	677W	682W	688W	693W	699W	704W
Open Circuit Voltage	49.05V	49.35V	49.55V	49.75V	49.95V	50.15V	50.35V
Short Circuit Current	17.43A	17.47A	17.52A	17.57A	17.62A	17.69A	17.74A
Maximum Power Voltage	40.66V	40.86V	41.06V	41.26V	41.46V	41.66V	41.86V
Maximum Power Current	16.50A	16.57A	16.61A	16.67A	16.71A	16.78A	16.82A

## TEMPERATURE CHARACTERISTICS

NMOT	41±3°C	Temp Coefficient of ISC	+0.046%/°C
Temp Coefficient of VOC	-0.25%/°C	Temp Coefficient of Pmax	-0.30%/°C

## PACKING CONFIGURATION

Modules/Pallet	37 Pieces	Modules/40'Container	740 Pieces
Packing Description	20 Pallets, Total=(37+37)x10=740 Pieces		

## CHARACTERISTICS

LP182\*210-M-66-NB-620W

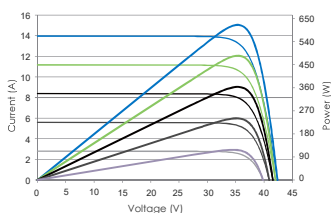

LP182\*210-M-66-NB-620W

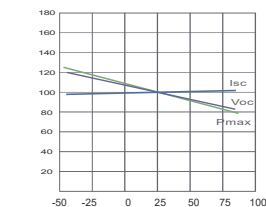

## MAXIMUM RATING

Output Tolerance	0~+5W
Operating Temperature	-40°C~+85°C
Wind Load/Snow Load	2400pa/5400pa
Fuse Current	25A

